

BASIC CONDENSER MOUNTING INSTRUCTIONS

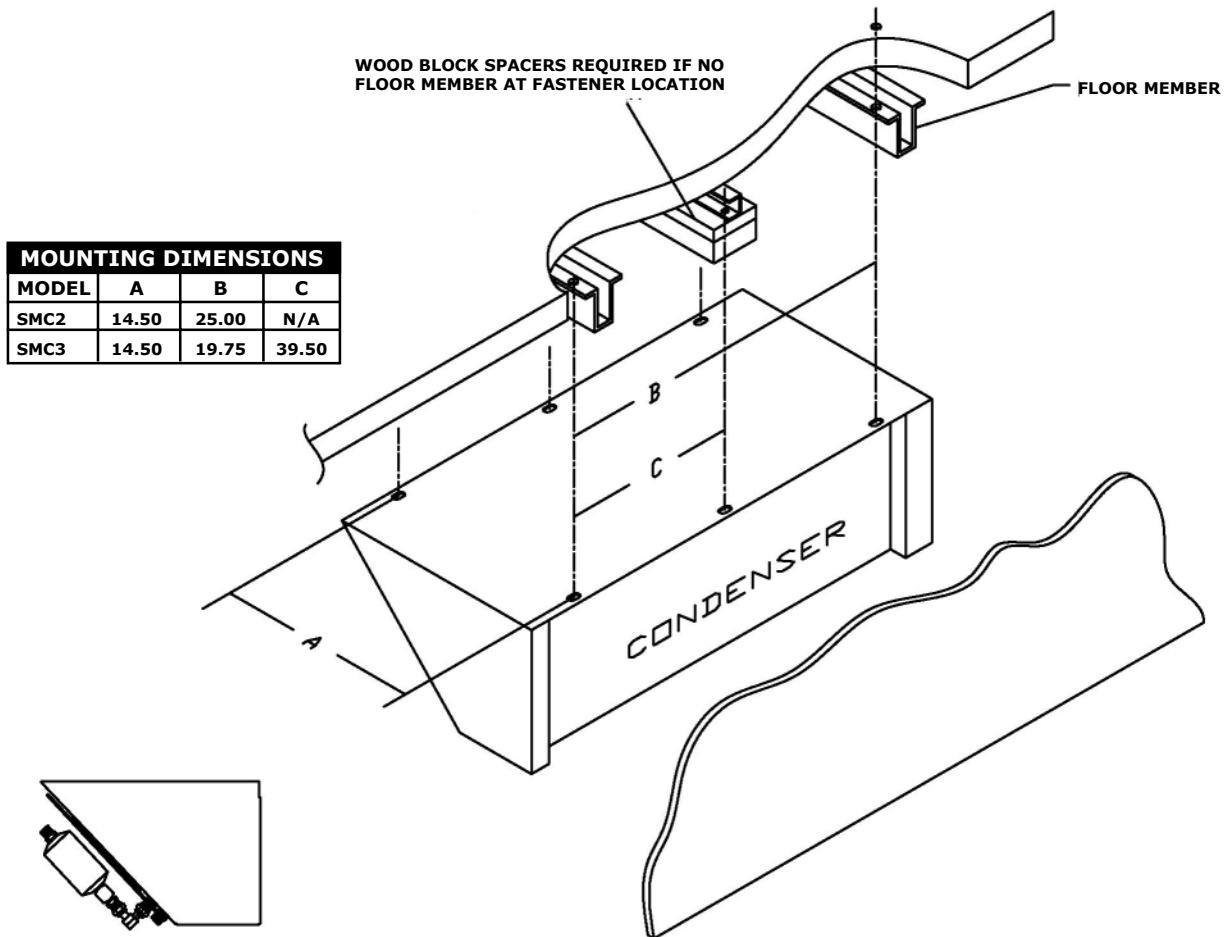

SMC2 - (4) 5/16-18 X 1.0 Bolts with USS Flat Washers and Lock Nuts Provided.
SMC3 - (6) 5/16-18 X 1.0 Bolts with USS Flat Washers and Lock Nuts Provided.